

Data Sheet



Article number: 201355121

Description: E+G Klee vertical clamp
GN 820.1-455-N forked clamping arm

Measures

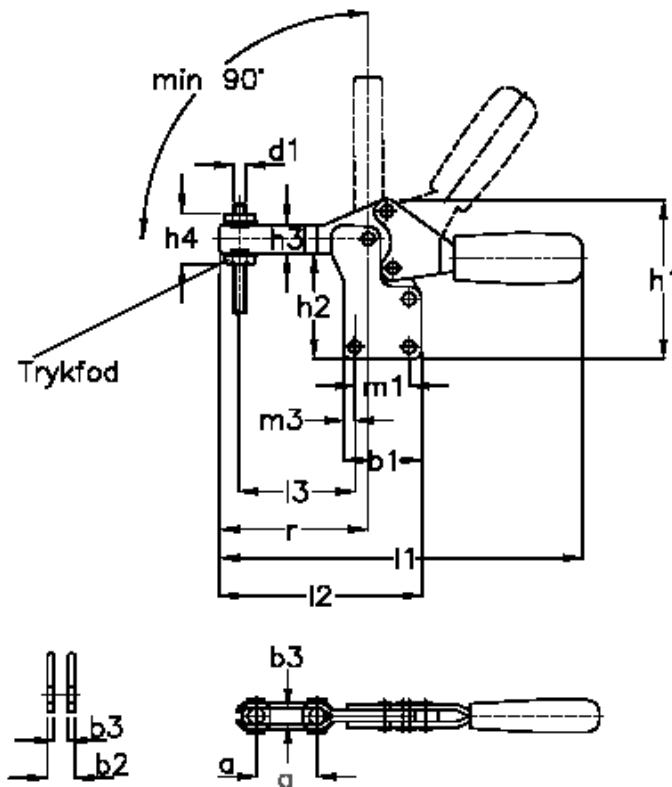

| | | |
|------------|------------------------|------------|
| a = 65 | h2 = 80.5 | m2 = 11.8 |
| b1 = 70 | h3 = 26 | m3 = 14.2 |
| b2 = 18 | h4 = 53 | r = 126.0 |
| b3 = 10 | Holding force N = 6200 | s = 10 |
| b4 = 12.4 | l1 = 309 | Size = 400 |
| d1 = M12 | l2 = 184 | |
| d2 = 8.5 | l3 = 116.0 | |
| h1 = 119.0 | m1 = 41.5 | |